



An Introduction to Weed Management for Conservation Tillage Systems

PLANNING A WEED MANAGEMENT PROGRAM

Managing weeds in reduced-tillage systems requires a planned approach. Through planning, successful conservation tillage producers anticipate potential problems, find timely solutions, and make use of integrated pest management techniques (IPM), such as field scouting and crop rotation, to find alternative pest management strategies. Flexibility and foresight also aid in success.

This fact sheet discusses ways to manage weeds and other vegetation in conservation tillage systems using cultural, mechanical, and chemical control tactics. See individual commodity sections within the *Penn State Agronomy Guide* or related publications for specific weed management guidelines for corn, soybeans, small grains, and forages.

Several factors make weed management in conservation tillage unique. In reduced-tillage agriculture, growing vegetation may already be present at planting time and must be killed or suppressed. Certain types of weeds are more common in no-till and may require special consideration. If weed pressure or plant residue is intense, an adjustment in herbicide rate or alternative control strategies may be required. Occasional use of selective tillage may be necessary to keep problem weeds in line. Finally, other management techniques, such as crop rotation, are critical.

VEGETATION CONSIDERATIONS

To establish a new crop in conservation tillage systems, it is necessary to kill or suppress emerged vegetation before or at planting time. “Preplant” vegetation can include a fall-seeded cover crop or an old grass or alfalfa hay crop; or it can simply be weeds that emerge prior to crop

establishment. Managing such vegetation in no-till systems generally means using a herbicide, but in reduced-till it can also involve chisel plowing, field cultivating, or disking, depending on the desired tillage system. Which control strategy to use will depend on several factors, including the emerged species, timing of control, and how much tillage the grower wants to do.

Cover Crops

Cover crops often require additional attention in conservation tillage systems. Winter annual cover crops, such as hairy vetch (*Vicia villosa*) or cereal rye (*Secale cereale*), can provide excellent cover when properly managed; they may even help to reduce the presence of certain problem weeds. Living mulches like crown vetch (*Coronilla varia*) can provide long-term soil management benefits without the need for annual establishment.

Weed Management Factors in Conservation Tillage

- Vegetation may be present at planting time
- Certain weeds are more common
- Herbicide rate may require adjustment
- Selective tillage may be necessary
- Crop rotation is critical for managing problem weeds

Mismanagement or neglect of any cover crop, however, can lead to additional weed problems and the potential for significant losses in crop yield. See the fact sheet entitled “Cover Crops for Conservation Tillage Systems” for more information on cover crop management.

Weeds

Certain traits help define what we call weeds. A characteristic of many weeds is the ability to invade and succeed under almost any environment. Certain habitats favor certain weeds, and conservation tillage provides a specific habitat.

Annuals

Annual weeds emerge from the soil, produce seed, and die in a single season or less than one year. There are two types: winter and summer annuals. Winter annuals begin growth in late summer or early fall and set seed in spring before dying. Table 1 includes examples of these and other types of weeds. Summer annuals have a life cycle that begins in late spring and ends in late summer or fall. Examples are the foxtails, fall panicum, large crabgrass, and small-seeded broadleaved weeds such as pigweed and lambsquarters (Table 1).

Some annual weeds can germinate with little or no seed burial and are common to no-till environments. In general, the smaller the seed, the more adapted the plant is to a reduced-tillage environment. These problem annual weed species tend to be

prolific seed producers; they germinate readily under crop residue, and depending on species, can emerge in the cool soils of April or May or during the warm summer rains of July. Their primary means of spread is by seed production.

Biennials

Other weeds that thrive under reduced-

tillage conditions are the biennials. These weeds, which include burdock, musk, and plumeless thistle, have a two-year life cycle (Table 1). Biennials emerge from seed and exist as low-growing rosettes the first year. The following spring or summer, biennial plant stems elongate, flower, and produce seed, ending their two-year life cycle. Biennials usually have a large taproot that extends deep into undisturbed soils of no-till fields. Like annuals, biennials reproduce and spread only by seed.

Perennials

Perennial plants live for more than two years. Many reproduce and/or spread through vegetative means as well as by seed. Perennials thrive in soils with little or no tillage where vegetative reproduction can allow a few plants to become a large community within a short time.

The simple perennials, such as dandelion and the dock species (Table 1), have one main taproot and spread principally by seed. Creeping perennials spread by rhizomes, budding roots, stolons, tubers, bulbs, or corms; they include Canada thistle, quackgrass, and even woody perennials like wild blackberry (Table 1). Some perennial species were once thought to be harmless or even aesthetically pleasing. An example is Japanese knotweed, which now shows up as a weed in no-till environments.

OPTIONS FOR WEED MANAGEMENT

An important benefit of tillage is weed control. In conservation tillage agriculture, the grower relies on the same weed management practices as in more conventional tillage systems but eliminates most or all of the tillage operations. Therefore, in limited tillage systems, there is greater dependence on cultural and chemical control options.

Cultural Weed Control

Cultural weed control may include altering cropping patterns or rotations; row spacing; planting or harvesting date; variety selection; and fertility practices. These strategies may be well-planned events, such as crop rotation, or simply preventive techniques that are more

subtle and spontaneous. Spot spraying or hand removal of an isolated infestation can prevent further spread of problem weed species, generally requiring little time or capital investment. In contrast, rotation to a small grain or forage crop to interrupt weed life cycles or altering the row spacing on a planter to increase crop competition over weeds can involve more time and money. Regardless of the level of input, cultural weed control strategies reap long-term benefits.

Crop rotation may have the largest single impact on weed control. No-till producers who raise continuous or multiyear corn, soybeans, or forages can expect to have greater weed problems and to invest more time and money in weed control than their neighbors who practice a more diverse rotation. Regard-

less of tillage system, crop rotation can provide an opportunity to manage some problem weeds effectively.

Fall-seeded cereal grains like wheat are very competitive against summer annual weeds that become common in corn or soybeans. Including a fall- or spring-seeded small grain in the rotation can allow timely herbicide applications for perennial weed management following the small grain harvest. Rotation to forages where repeated mowing is part of the management strategy will reduce the frequency of certain annual and perennial weeds. Grass forage and hay crops can be very competitive and can permit the application of several effective broadleaved herbicides. Crop rotation's benefits are diverse and run well beyond the realm of weed management.

Table 1. Common weeds in no-till systems.

Winter annuals	Summer annuals
Common chickweed	Common lambsquarters
Henbit	Pigweed spp.
Red dead nettle	Foxtail spp.
Shepherdspurse	Fall panicum
Field pennycress	Large crabgrass
Wild mustard	Common ragweed
Yellow rocket	Velvetleaf
Wild radish	Annual smartweed
Pepperweed spp.	Eastern black nightshade
Downy brome	Jimsonweed
Horseweed/marestail	Rough (daisy) fleabane
Prickly lettuce	Creeping perennials
Biennials	Canada thistle
Common burdock	Hemp dogbane
Bull thistle	Bindweed spp.
Musk/plumeless thistle	Common milkweed
Wild carrot	Horsenettle
Wild parsnip	Quackgrass
Poison hemlock	Wirestem muhly
Common mullein	Johnsongrass
Simple perennials	Yellow nutsedge
Common dandelion	Wild garlic/onion
Dock spp.	Virginia creeper
Common pokeweed	Wild blackberry
	Sumac spp.
	Japanese knotweed

Mechanical Weed Control

Mechanical weed control includes tillage and mowing. Except in strict no-till situations, many producers still rely on some mechanical control within the rotation. Mulch-tillage systems often depend on tillage prior to planting. Although chisel plows, disks, and field cultivators generally are not as effective as the moldboard plow, they can help suppress weed populations and still maintain a certain level of surface plant residue. These "less aggressive" tillage tools kill emerged weed seedlings but are less effective in burying weed seeds beneath their maximum depth of emergence (see Table 2) or in disrupting perennial vegetative structures.

In general, most

small-seeded weeds (e.g., foxtail, pigweed) germinate and emerge within the upper half inch of the soil surface. Larger-seeded broadleaves (e.g., cocklebur, burcucumber) generally can germinate from soil depths of 1 1/2 inches or greater. For lasting benefit in conservation tillage systems, tillage must be used in conjunction with other strategies such as effective herbicide programs and crop rotation. Disking or chopping up the perennial root system without effective follow-up measures may actually increase the weed problem. But tillage combined with an effective systemic herbicide application can have a greater impact on weeds than either tillage or herbicide alone.

Cultivation and Specialized Tillage Systems

Row Crop Cultivation

Row crop cultivation is a good complement to chemical weed control. In fact, producers who wish to enhance weed control or reduce herbicide use may find an alternative management tool in cultivation. Two or more passes with the cultivator may be necessary, but cultivation can allow for reduced herbicide rates, especially when the herbicide is banded. The first cultivation should be done early, so as not to prune crop roots, and deep enough (4-6 inches) to kill weeds and loosen soil. Weeds should be shorter than 4 inches and the crop tall enough (greater than 6 inches) to avoid being buried under soil or crop residue.

The second cultivation should be done when the crop is under 24 inches tall to allow the cultivator to pass through and avoid disturbing the root system. This single later cultivation may suffice if early weeds have been controlled with herbicides. Combining mechanical and chemical methods is economical and effective.

High-residue row crop cultivators can be used to help manage small annual weeds in reduced-tillage systems. Conservation tillage cultivators are relatively heavy and made to pass through larger amounts of surface residue while dislodging emerged weed seedlings.

Ridge-Till Systems

High-residue cultivators are the backbone of weed control programs in ridge-tillage systems. Weed control and conservation practices such as residue management can be maintained by cultivation and/or herbicide application. In ridge-till, weed seeds and “trash” are removed from the ridge and deposited between the rows. Ridge-till equipment can move as much as 70 percent of the

previous year’s weed seed out of the crop row. The remaining weeds within the row can be controlled by band applications of herbicides, while between the row weeds may be removed with cultivation.

In general, two trips with a cultivator are necessary for successful control. Most current models of conservation tillage cultivators include ridging tools along with standard high-residue

sweeps (see Figure 1). Because of their weight, high-residue cultivators require a fair amount of lifting and pulling power (horsepower), and most models come with guidance systems that can help prevent damage to the crop. Regardless of the type of cultivator, cultivation on highly erodible land can be challenging even when a guidance system is being used.

Mulch-Till Systems

Mechanical operations in mulch-till systems are

Table 2. Optimum and maximum seed emergence depth of several weed species.

Weed	Optimum (inches)	Maximum (inches)
Common lambsquarters	0.2-0.4	2.0
Canada thistle	0.4	2.4
Common chickweed	0.4	0.8
Crabgrass	0.4	1.6
Giant foxtail	0.2-0.6	1.2
Green foxtail	1.0	3.0
Burcucumber	1.0-2.0	6.0

Sources: King 1966 and Mann 1981.

Figure 1. Components of a conservation tillage cultivator.

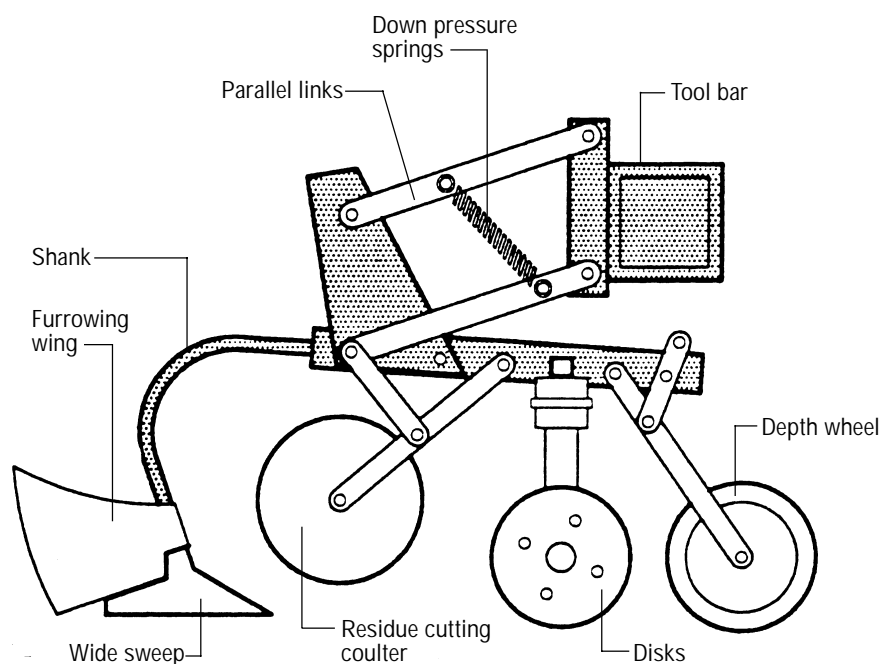

designed to leave 30 percent or more residue on the soil surface. Generally, no more than two passes with a chisel plow, disk, or field cultivator are needed before planting. For maximum weed control, one operation is performed early (fall or early spring) and the second is completed as late as possible (immediately before planting). For greater effectiveness, the second operation should be delayed until the soil warms and the initial flush of germinating weed seeds has emerged. With the less frequent and intense tillage of the mulch-till system, certain weed problems may increase. An effective herbicide program and/or cultivation must compensate for this.

Except for in-ridge tillage, post-planting tillage operations such as rotary hoeing or row cultivation are seldom used in conservation tillage systems. The rotary hoe can be effective for controlling emerging weed seedlings in corn or soybeans in conventional systems. However, the rotary hoe was designed for use in low-residue environments and encounters problems as surface residue increases. While the rotary hoe may have a place in some mulch-tillage systems, it is not a dependable weed control tool in higher-residue environments.

Mowing

Mowing can be effective for managing certain cover crops and some weed species. Managing weeds with mowing is generally limited to forage or pasture situations. Frequent mowing (every 30 to 60 days) can reduce perennial weed competition and longevity as well as prevent seed production for many types of weeds. It can also prevent the spread of troublesome weeds into cultivated fields.

When properly timed, mowing can successfully control certain cover crops before the primary crop is planted. Mow legume cover such as hairy vetch after the first purple flowers appear. Mow cereal grains after heading to ensure adequate control. Mowing cover crops like hairy vetch or cereal rye prior to flowering can fail to provide adequate control and could result in severe competition with the primary crop.

Chemical Weed Control

Chemical weed control remains an important pest management tactic in reduced-tillage agriculture. Regardless of how effective cultural control strategies are, herbicides provide a way to manage weeds successfully with little or no tillage. Which type of control method to use depends on the tillage system. More options are generally available for mulch-till than for no-till situations. Chemical approaches are based on timing of herbicide application and include burndown, soil residual, and postemergence treatments.

Burndown Herbicides

Burndown herbicides kill or suppress live vegetation present at planting time. The need for and selection of a burndown herbicide depends on the type and quantity of vegetation. Burndown herbicides are either systemic or contact-type. Systemic herbicides are absorbed by plants (roots or leaves) and move throughout the plant with water (“xylem-mobile”) or with sugars (“phloem-mobile”). Phloem-mobile herbicides include glyphosate (Roundup or Touchdown), 2,4-D, and dicamba (Banvel). These chemicals are generally used to kill larger annual and perennial grasses or broadleaves like alfalfa or other hay or pasture crops.

Contact herbicides including paraquat (Gramoxone Extra) are not mobile in the plant and kill only the tissue surface contacted by the spray. A burndown application of paraquat is well suited for smaller annual weeds or younger cereal grain cover crops. In corn or soybeans, soil residual broadleaved herbicides may also serve as all or part of the burndown program if only certain annual weed seedlings are present at planting time. Emerged weed seedlings not destroyed by tillage or a burndown application may subsequently be more difficult to control because of greater size or maturity. Specific burndown and other herbicide information can be found in more detail under the individual commodity sections within the *Penn State Agronomy Guide* or related publications on corn, soybeans, small grains, and forages.

Soil-applied Herbicides

Soil-applied herbicides, such as atrazine and Dual or Lasso, are generally applied before the weed or crop emerges. The timing of herbicide applications can be classified by the number of days ahead of planting as early preplant, preplant, or preemergent. Soil-applied products are mostly xylem-mobile systemics that are taken up by the roots (or shoots) of germinating seedlings. They are used primarily to prevent annual weed emergence or growth in annual cropping systems by maintaining “residual” activity over an extended period.

“Soil residual” herbicides generally are those supplying at least four weeks of weed control. Many of the same soil residual herbicides used in conventional tillage systems are also used in reduced-tillage systems. There is one exception—herbicides that must be mechanically incorporated are impractical in no-till environments—but incorporation of products may still be possible in reduced-tillage systems. Herbicide treatments can be mechanically incorporated in mulch-till systems, allowing for more herbicide options than no-till preemergence treatments. Regardless of tillage system or timing, soil residual herbicides depend on rainfall for mobilization and even distribution in the soil and subsequent uptake by germinating weeds.

Application Timing for Soil-applied Herbicides

In conservation tillage systems, soil residual herbicides are applied to crops early preplant, preplant, or preemergence. One way to avoid using a burndown herbicide in corn or soybeans is to make early preplant applications (EPP). An EPP application is simply applying the residual herbicide(s) 15 to 30 days ahead of planting. Ideally the herbicide is applied in the spring, before new vegetation has emerged. Care must be taken, however, to avoid applying the herbicide too early or residual control may be inadequate. In general, an application about 10 to 15 days ahead of planting is plenty of lead time. EPP herbicide application rates may require a

slight increase over conventional application rates (10 to 25%). Check the herbicide label for appropriate EPP rates.

Effects of Increased Plant Residue

In reduced-tillage systems, greater amounts of plant residue can affect the performance of soil residual herbicides. When planting into heavy residue, be sure the seed furrow closes completely and the germinating crop seed does not remain exposed to the subsequent herbicide spray. This is especially true if you are using herbicides like pendimethalin (Prowl) or applying a product that contains dicamba (Banvel, Clarity, or Marksman) or 2,4-D preemergence.

Where weed pressure is heavy and/or plant residues are high, you may need to adjust the residual herbicide rate. Herbicide sprays may be initially intercepted by plant residues and remain bound to them until sufficient rainfall is received. In addition, residue may act as a physical barrier during herbicide application, making uniform spray coverage difficult.

There are few clearcut rules about herbicide rates under conditions of high plant residue, but several herbicide labels recommend an increase in rates. In heavy crop or weed residue situations, check the herbicide label for specific rate guidelines. In general, residual herbicide rates for grasses may need to be increased 10 to 25 percent above rates for conventional tillage systems if large amounts of plant residue and/or heavy weed pressure exist. Specifically, if severe populations of foxtail or fall panicum are anticipated, grass herbicide rates may need to be increased or the application timing altered to include split applications or postemergence control. Remember that herbicide rates are not based solely on the amount of surface residue, however, but on other factors as well.

Selecting Herbicide Rates

Before selecting the correct soil-applied herbicide rate, consider:

- soil texture and organic matter—soils with higher percentages of clay and

organic matter require higher herbicide rates.

- soil texture and proximity to groundwater—coarse or sandy soils, high water tables, or wells close to fields may dictate that lower rates or different products be used. Generally, low solubility, low persistence, or postemergence herbicides may be used to avoid groundwater contamination.
- surface residue—high amounts of surface plant residues may require higher herbicide rates.
- soil moisture—rainfall is needed to move the herbicide into germinating weed seed zones; reduced rates are particularly subject to failure without adequate soil moisture.
- application timing—early preplant applications may require higher rates.
- severity and types of weeds—larger weeds and/or perennials may require higher herbicide rates.

Postemergence Herbicides

The performance of postemergence or foliar-applied herbicides is generally unaffected by tillage system, so application rates are the same as for conventional tillage systems. In general, apply postemergence herbicides when annual weeds are young and most susceptible to the herbicide spray. As is true for soil-applied herbicides, the effectiveness of postemergence products depends on weather. Rainfall shortly after application or drought stress on weeds may reduce herbicide absorption by plant tissues.

Postemergence applications offer some control of perennial weeds. Applications 3 to 6 weeks after corn or soybean planting will suppress weeds like hemp dogbane, horsenettle, and Canada thistle. Broadleaved perennials, however, are most susceptible to a systemic herbicide application as they approach their flowering period. Unfortunately, this period usually coincides with the time when corn is 4 to 6 feet tall and soybeans are in full bloom—not an appropriate time to apply a postemergence herbicide.

For most perennial broadleaved weeds in spring-seeded crops, reducing

the competitiveness of the weed in the current year's crop is the most that can be expected from a timely herbicide application. Perennial weed management requires a diverse crop rotation along with the use of selective herbicides.

In summary, managing weeds in reduced-tillage systems may present a challenge. But successful growers anticipate potential problems through planning and field scouting, applying timely solutions, and using crop rotation to present alternative pest management strategies. Remember, foresight and flexibility are keys to success.

REFERENCES

- Mann, R. K., C. E. Rieck, and W. W. Witt. 1981. Germination and emergence of burcucumber (*Sicyos angulatus*). *Weed Sci.* 29(1), 83-86.
- King, L. J. 1996. *Weeds of the World: Biology and Control*, Interscience Pub., New York, NY.

Prepared by William S. Curran, associate professor of weed science, Dwight D. Lingenfelter, extension assistant, and Lyn Garling, project associate

Penn State College of Agricultural Sciences research, extension, and resident education programs are funded in part by Pennsylvania counties, the Commonwealth of Pennsylvania, and the U.S. Department of Agriculture.

Where trade names appear, no discrimination is intended, and no endorsement by Penn State Cooperative Extension is implied.

Issued in furtherance of Cooperative Extension Work, Acts of Congress May 8 and June 30, 1914, in cooperation with the U.S. Department of Agriculture and the Pennsylvania Legislature. J. L. Starling, Acting Director of Cooperative Extension, The Pennsylvania State University.

This publication is available in alternative media on request.

The Pennsylvania State University is committed to the policy that all persons shall have equal access to programs, facilities, admission, and employment without regard to personal characteristics not related to ability, performance, or qualifications as determined by University policy or by state or federal authorities. The Pennsylvania State University does not discriminate against any person because of age, ancestry, color, disability or handicap, national origin, race, religious creed, sex, sexual orientation, or veteran status. Direct all inquiries regarding the nondiscrimination policy to the Affirmative Action Director, The Pennsylvania State University, 201 Willard Building, University Park, PA 16802-2801; tel. (814) 863-0471; TDD (814) 865-3175.